

Protek 608

50,000 Count, Advanced DMM



Protek

TABLE OF CONTENTS

1. INTRODUCTION	1-1. MAIN FEATURES	4
	1-2. FRONT PANEL DESCRIPTION(LCD,KEY,ROTARY,SOCKET)	5
	1-3. REAR PANEL DESCRIPTION(RS232C,TILT-STAND,BATTERY)	6
2. MODE KEY OPERATION		7
3. OPERATING	3-1. POWER ON/OFF	9
	3-2. DCmV,DCV	9
	3-3. ACmV,ACV, AC + DCmV,AC + DCV	10
	3-4. DCuA,DCmA,DCA	10
	3-5. ACuA,ACmA,ACA, AC + DCuA,AC + DCmA,AC + DCA	11
	3-6. ohm, CONTINUITY, L _V ohm	11
	3-7. nS	12
	3-8. ZENER DIODE	12
	3-9. CAPACITANCE	13
	3-10. Hz	14
	3-11. PULSE WIDTH	14
	3-12. TEMPERATURE	15
4. RS232C INTERFACE	4-1. CONNECTION BETWEEN PC & METER	16
	4-2. RS232C CABLE & PIN CONNECTION	16
	4-3. COMMUNICATION SPEC.	16
	4-4. INSTALLATION	17
	4-5. OPERATION	17
5. SPECIAL FUNCTION DESCRIPTION	5-1. AUTO OFF	18
	5-2. LOW BATTERY INDICATION	18
	5-3. BAR GRAPH DISPLAY	18
	5-4. MAX/MIN	18
	5-5. ± PEAK	18
	5-6. AVERAGE	19
	5-7. GO/NG	19
	5-8. STORE	20
	5-9. RECALL	20
6. MAINTENANCE	6-1. GENERAL	21
	6-2. BATTERY REPLACEMENT	21
	6-3. FUSE REPLACEMENT	22
	6-4. CALIBRATION	23
7. APPENDICES	7-1. GENERAL SPECIFICATION	25
	7-2. ELECTRICAL SPECIFICATION	27
	7-3. RANGE SWITCHING BY FUNCTIONS	33
	7-4. MODE SELECTION BY FUNCTIONS	34
	7-5. SPECIAL SYMBOLS ON LCD	35
	7-6. LCD STATUS BY FUNCTIONS	36
	7-7. LCD STATUS BY MODES	37
	7-8. ASSEMBLY DIAGRAM	39
	7-9. SAFETY	42
	7-10. REPLACEMENT PARTS LIST	43
*PROTOCOL		44

1 INTRODUCTION

1-1. MAIN FEATURES

- 1) 0.05% basic accuracy, 50,000 count resolution with 50ms sampling time featuring 4th order delta-sigma analog to digital conversion and a variety of useful functions makes the 608 by far the best hand-held DMM available today.
- 2) DCmV measurement function has 0.05% accuracy and more than 1Gigaohm of input impedance. A wide 0 to 2500mV full scale measuring range with a Resolution of 10 uvolts enables accurate and precise measurements.
- 3) Large LCD with 67x47mm of viewing area, a dual 5 digit display, 54 annunciators and An Electro-luminescent back light with an innovative bar-graph based on binary bit expression, which gives immediate perception of minute changes in signal levels and an easy understanding of binary code.
- 4) Zener diode function for testing Zener diodes from 0 through more than 15V, together with low voltage ohm & conductance (nS) test functions, provides very easy and powerful circuit analysis ability in electronic test and measurement work.
- 5) Pulse width, Duty cycle & Hz measurement functions, used together with other basic functions, provides very useful testing ability in applications such as automotive testing etc.
- 6) 10 locations of nonvolatile EEPROM permanently stores data without a backup battery or applied power.
- 7) Auto power off function for saving energy.
- 8) Designed for safety and to prevent electrical shock.
- 9) Holster for rugged use is included.
- 10) RS232C computer interface enables data to be captured and transferred to a PC for processing and storage.

1-2. FRONT PANEL LAYOUT

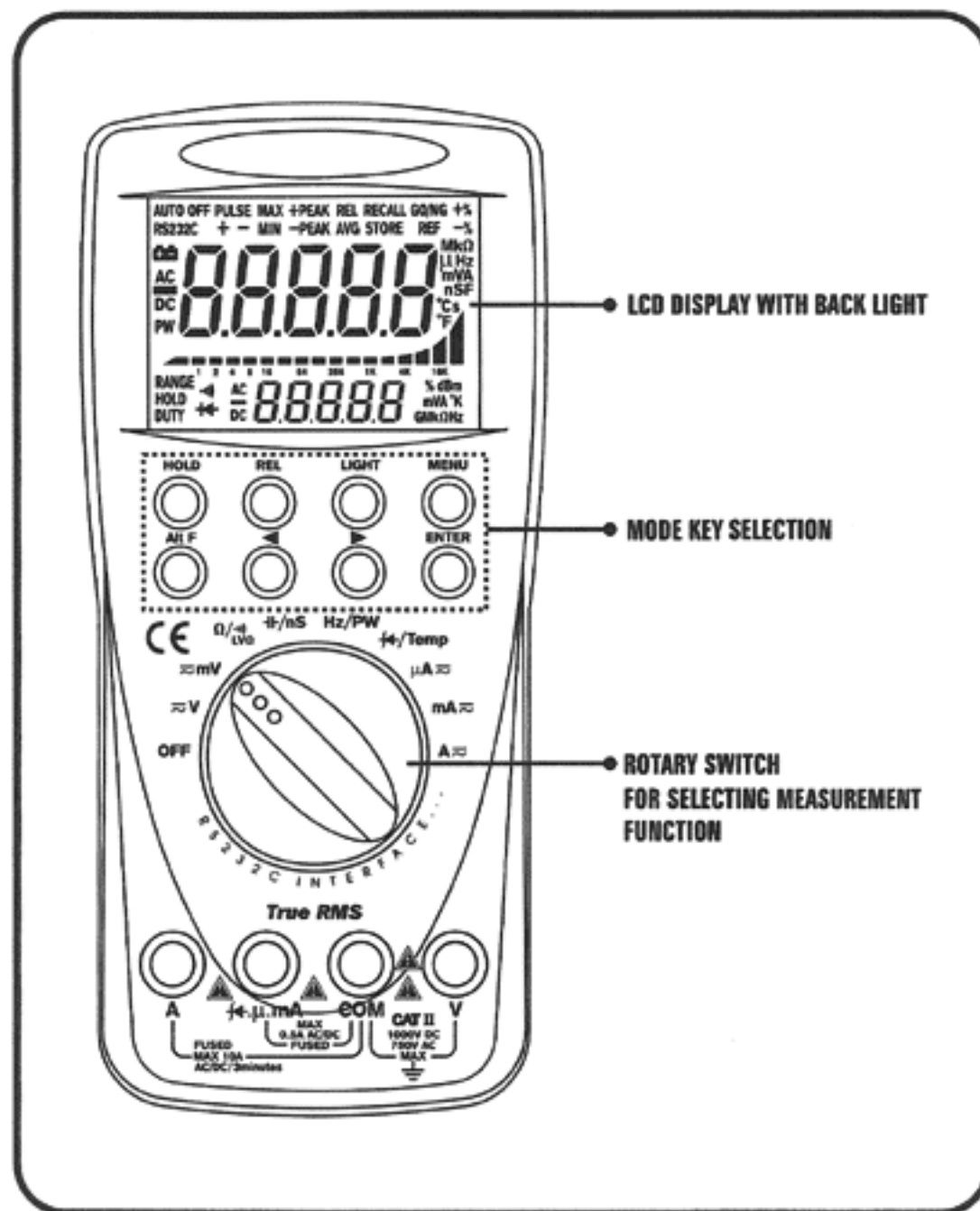

1-3. REAR PANEL LAYOUT

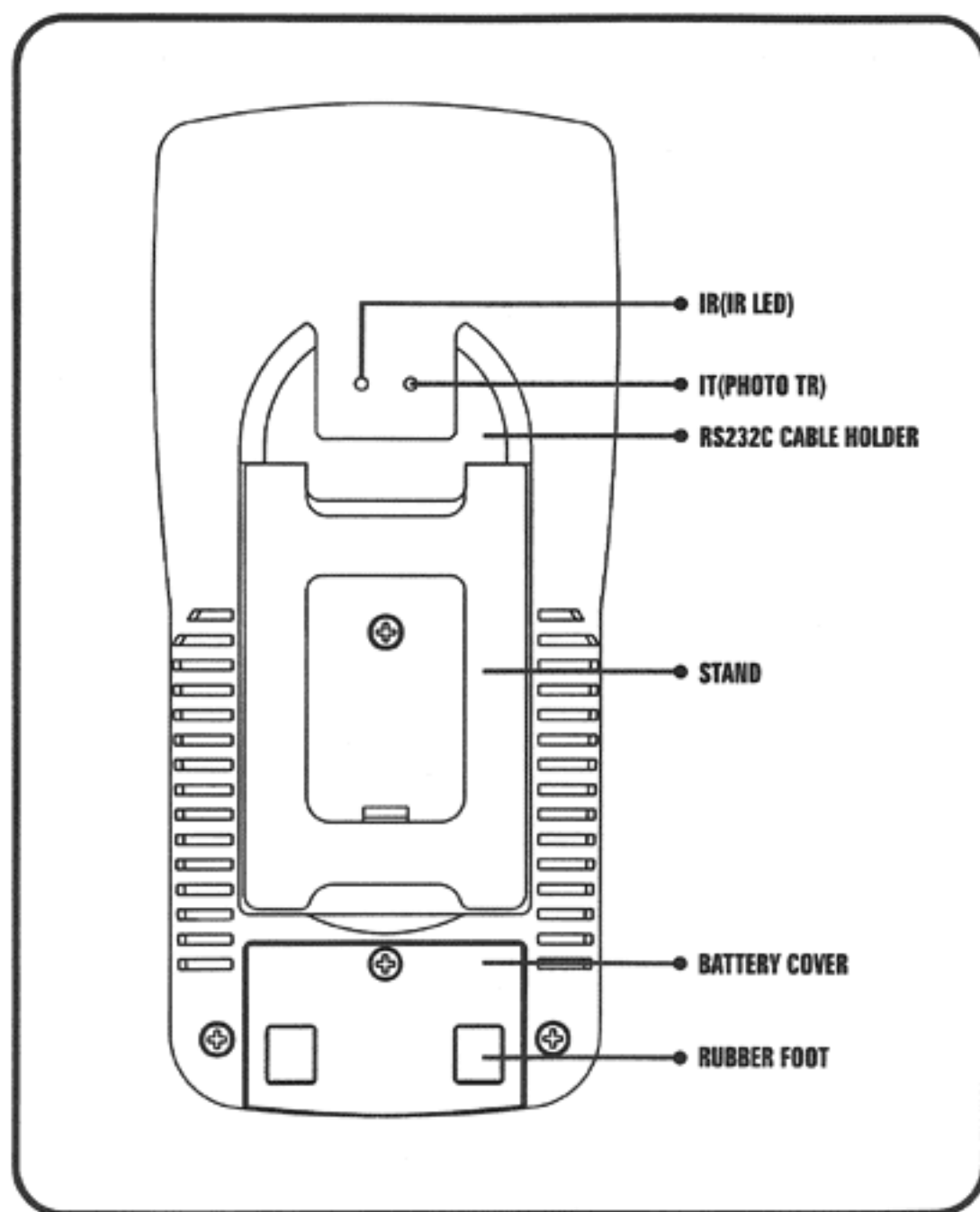
**WARNING**

READ THE "SAFETY" IN APPENDICES BEFORE USING THE METER.

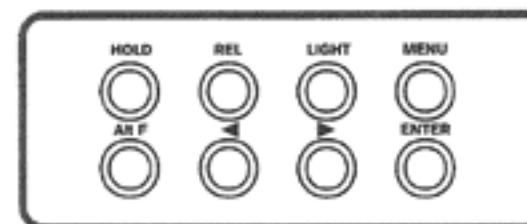
2 MODE KEY OPERATION**2-1. HOLD**

This key when pressed 'freezes' the measurement reading on the LCD, no further updates to the LCD display will happen and the HOLD annunciator turns. Pressing the HOLD key again restores the DMM to normal operation.

2-2. REL

The relative mode allows the operator to measure values with respect to a reference value other than zero. The relative value is computed by the equation: $\text{Relative} = \text{measured} - \text{reference}$

Pressing the REL key enters the measured value on the LCD as the reference and displays the REL annunciator. Pressing the ENTER key only while in the REL mode updates the Reference Value.

- Press the REL key to enter the measured value on the LCD as the relative value and to display the REL symbol.

Pressing the REL key again releases the relative mode and returns the DMM to the normal mode of operation

Note

- 1) The REL mode can only be used for numerical data; it cannot be used for continuity, which displays open or short instead of numbers.
- 2) The REL mode is especially useful for low ohms measurement, which requires the test lead resistance to be cancelled.

2-3. LIGHT

Pressing this key turns on the LCD back light; pressing the back light key again will turn it off. In order to conserve battery power the backlight will automatically shut off 30 seconds after it is turned on.

2-4. MENU

Pressing this key places the meter in the menu mode. Pressing this key again the meter will exit from the menu mode and return to the previous operation.

Once the meter is in the menu mode, all the menu annunciators appear on the upper portion of the LCD with the flashing cursor over one annunciator. To select the desired menu item, press the Left or Right (or) keys until the flashing cursor is over the desired annunciator, then press the ENTER key to select. The exception to this procedure is the GO/NO Testing function, which is explained in detail in chapter 5 sections 5-7 of this manual.

2-5. ALT - F

This key is used for selecting the alternate functions, which share the same position on the rotary function switch (e.g. Hz/PW). When the Function selector switch is rotated to this position the default function is HZ. Pressing the ALT-F function key will select PW (pulse width)

2-6. LEFT

This key is used to select the manual range mode and shift the present measurement range one decimal place to the left. Each time this key is pressed the decimal point will shift one place to the left. Pressing this key in the Menu mode will cause the blinking cursor to move to the left.

2-7. RIGHT

This key is used to select the manual range mode and shift the present measurement range one decimal place to the right. Each time this key is pressed the decimal point will shift one place to the right. Pressing this key in the Menu mode will cause the blinking cursor to move to the right.

2-8. ENTER

Pressing the ENTER key executes the function selected by the Right and Left Keys as described above in the menu mode. When pressed, the blinking annunciator will stop blinking and all the other menu items will disappear. If however, the "AUTO OFF" and "RS232C" annunciators had been selected previously they will remain on the LCD. Another important function of this key is to restore the power to the meter after AUTO POWER OFF has occurred.

3 OPERATING

3-1. POWER ON/OFF

When not used for very long time (a few months, etc), it would be better to shut off the unit with the function selector switch instead of depending on the auto power off, which draws about 70uA of battery consumption, or about 5 months of battery lifetime with commonly used types of 9V carbon/zinc batteries.

When the power switch is turned on, all the segments on the LCD display will appear (see Fig 1 on page 36) and the built in buzzer in the meter will sound for 1 second and then normal operation will be started and measurements may be now be obtained according to what the rotary function selector switch has been set to.

3-2. DCmV and DCV

- 1) Rotate the rotary selector switch to the mV or V position. The LCD screen will appear as shown in fig Nos. 2 and 5 on page 36 of this manual. If the alternate mode (AC or AC+ DC) has been selected (as indicated by the LCD Annunciators) press the ALT-F key to select DC.
- 2) Connect the red and black test leads into the corresponding colored input sockets and then connect the probe end of the test leads to the voltage source to be measured.
- 3) The LCD will display the measured value along with the corresponding bar graph value.
- 4) If the measured voltage is too high, the "OL" will appear. In this case, immediately remove the probes from the voltage source and determine the cause of the overload.
- 5) The secondary or lower display will indicates the meter's input impedance value

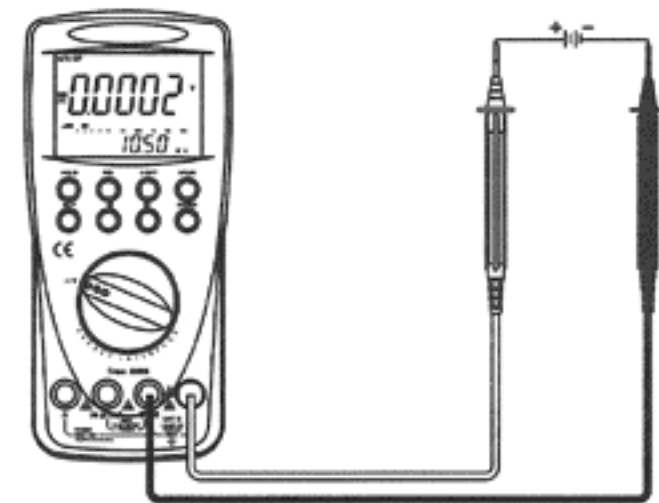

Direct Voltage Test

3-3. ACmV, ACV, AC+DCmV, AC+DCV

- 1) Rotate the Rotary selector switch to mV or V position, and then press the ALT-F key to display the AC annunciator on the left side of the LCD see fig. 3 & 6 on page 36) Pressing the ALT-F key again will display the annunciators for both AC and DC This is for the AC + DC true RMS mode. Pressing the ALT-F key 3 consecutive times will cycle the meter through the 3 voltage modes (DC, AC, AC+ DC)
- 2) Attach the probe tips to the voltage source.
- 3) The voltage measurement will appear on the display.
- 4) The Bar graph will display the voltage value as a binary bit expression.
- 5) If the measured voltage is too high, the measurement range will be changed automatically to the next higher range. When the measured voltage is greater than the highest range the display will read "OL".
- 6) The secondary digit display will read the decibel value based on 600 OHM impedance calculated by the following formula.

$$\text{dBm} = 20 \log(V/0.7746)$$

3-4. DCuA, DCmA, DCA

- 1) Select uA, mA or A with the rotary switch.
- 2) Press the ALT-F key to select DC if necessary.
- 3) Break the circuit where the current is to be measured.
- 4) Connect the two test leads to complete the broken circuit.
- 5) If the measured current is too high, the display will indicate "OL". In this case, the higher current range (mA or A) should be selected.
- 6) The bar-graph segments will indicate the measured value as a binary sequence.
- 7) The secondary display will show the shunt resistor value for calculating the insertion voltage drop caused by meter using the formula $V=IR$.
- 8)  The "A" input socket has a special function designed for safety, which is called the "WARNING BEEP". When the rotary switch is set up to any function other than the "Amps", inserting the test leads in the "Amps" socket will cause the warning beeper to sound. The "A (Amp)" input terminal allows current measurement continuously up to 5A or within 3 minutes for currents to 10A. Successive high current measurements above 5A require 10 minutes of cooling time between measurements.



WARNING

DO NOT MEASURE HIGH CURRENT OF MORE THAN 10A TO AVOID OPENING THE FUSE OR OVER HEATING THE PCB

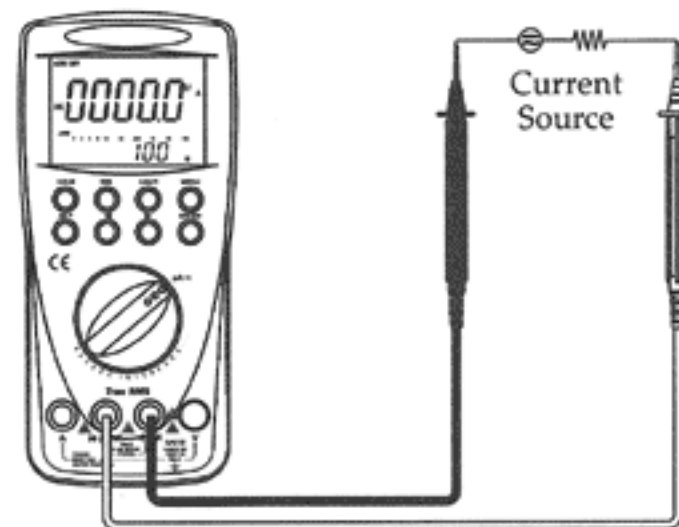

3-5. ACuA, ACmA, ACA, AC+DCuA, AC+DCmA, AC+DCA

- 1) Select uA, mA or A with the rotary switch. Press the ALT-F key once to select the AC mode. Pressing the ALT-F key again selects the AC+DC True rms mode.
- 2) Use the same procedure as described in section 3-4 (DC current measurements)

3-6. Ohm, CONTINUITY, Lo Volt ohm

- 1) Rotate the rotary selector switch to the OHMS position.
- 2) If the test leads are opened the display will read "OL".
- 3) Shorting the test leads will display zero or an extremely low value Resistance value, this is the test lead resistance.
- 4) Relative mode is useful to cancel this error by subtracting the test lead Resistance from the measured resistance.
- 5) The secondary display reads 2.5V if normal Ohms measurement has been selected, 0.25V if Lo Volt Ohms has been selected. These voltage values are the open circuit test voltage. If continuity is selected, the measured resistance value is displayed on the secondary display.
- 6) One of these 3 functions may be selected by pressing the ALT-F key until the desired annunciator is displayed on the lower left of the LCD.
- 7) The continuity function is useful for checking for open or short circuits. The resistance value is read on the secondary display while the main display reads either "OPEN" or "SHORT". The buzzer will sound when the display reads "SHORT". Pressing the LEFT or RIGHT key while in the continuity function increases or decreases continuity measurement range there by increasing or decreasing the resistance value, which turns the buzzer on or off. (See continuity specifications in the Appendices)

- 8) Lo Volt Ohms function is useful for accurate resistance measurements in a circuit, which includes semiconductor devices. There is no need to remove the resistor or semiconductor device from the circuit.

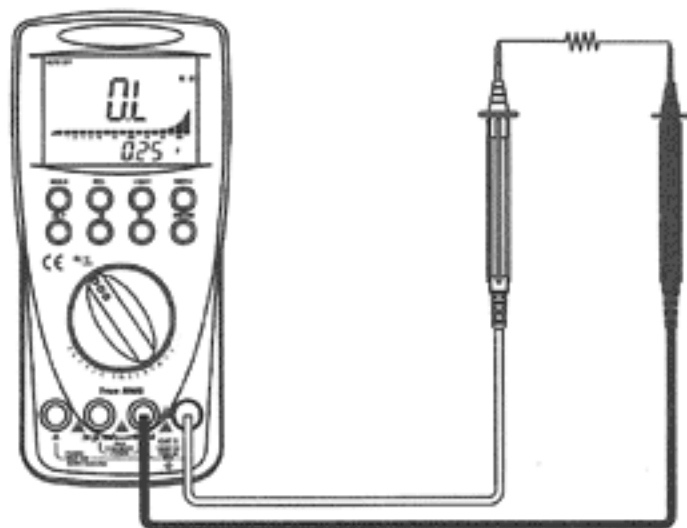

Resistance Test

3-7. nS (Conductance)

- 1) Rotate the function selector switches to the capacitance/nS position. Press the ALT-F key once to select the nS (conductance) function.
- 2) The secondary digit display reads the resistance value of the measurement in Gigaohms, while the primary display reads the conductance value in nanosiemans which is calculated from the equation, $S = 1/R$. This measurement function is very useful for checking extremely high resistances or leakage properties of insulation materials etc.

3-8. ZENER DIODE

- 1) Rotate the function selector switch to the Zener diode/Temp position. The Zener annunciator will appear on the lower left of the display.
 - 2) With the test leads open the primary display will read about 20V, this is the maximum open circuit test voltage. The secondary display will read 1mA, the constant test current.
- The Zener diode function is very useful for analyzing complex circuits that include semiconductor devices such as ICs, transistor, Zener etc. The Zener diode function has a test voltage much higher than the test voltage in the diode test, which is commonly seen, in most digital multimeters. This function along with Lo Volt Ohms function makes this instrument a powerful tool for various electronic circuit analyses.

- 3) Connect the black lead tip to the anode of the Zener diode under test and the red lead tip to the cathode. The Zener voltage will be displayed on the LCD. For diode test, connect the black lead tip to cathode of diode and the red lead tip to the anode. The diode's forward voltage drop will be displayed on the LCD.

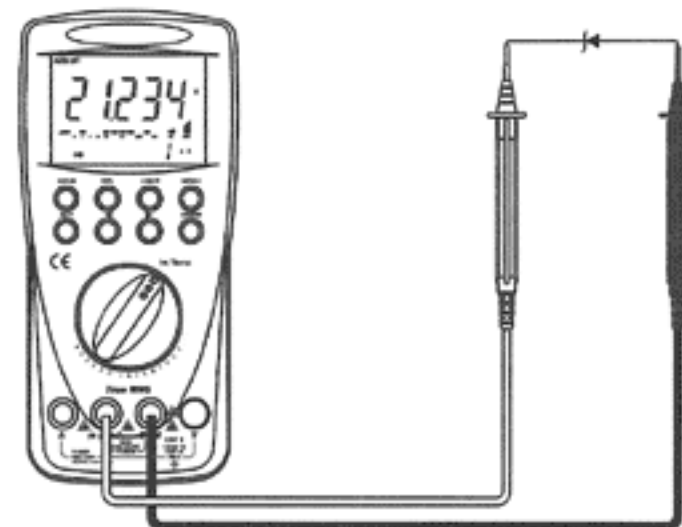

3-9. CAPACITANCE

- 1) Rotate the function selector switch to the capacitance position.
- 2) Discharge the capacitor to be measured.
- 3) Connect the test lead tips to the capacitor. Note: capacitors must be measured out of the circuit.

If the capacitor to be measured is an electrolytic type with polarity, the Red test lead should be connected to + lead of capacitor and the black to - lead of capacitor.

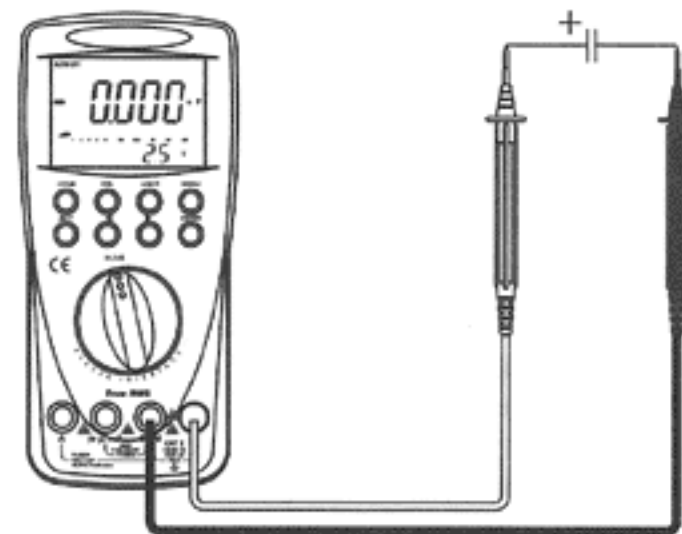

Note The secondary display reads the test voltage that the capacitor has charged to in this case the value is 2.5V. The capacitor is then discharged through a resistor circuit with values from 1.5k ohm to 1Megohm depending on the measurement range.

3-10. Hz

- 1) Rotate the rotary function switch to the Hz position.
- 2) Attach the test lead tips to signal source to be measured.
- 3) The main display will read the measured frequency.
- 4) Secondary display will read the AC voltage of the signal source. The voltage range of the secondary display is 0 to 500V with 10mV of resolution.
- 5) The AC voltage is specified to 20 kHz as shown on the AC mV & V specifications on page 27. When the measured frequency exceeds 20kHz, the secondary display is no longer useful due to the attenuation of the signal level.

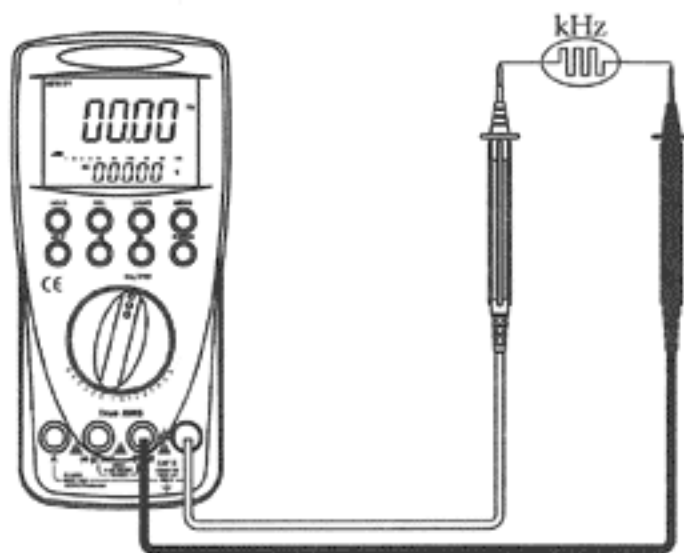

Frequency Measurement

3-11. ±PULSE WIDTH

- 1) Select Hz/PW with rotary switch. Press the ALT-F key once for positive pulse width measurement or twice for negative pulse width measurement.
- 2) Connect the test lead tips to the signal source to be measured.
- 3) The main display will read the measured pulse width.
- 4) The secondary display reads the percent duty cycle.

3-12. TEMPERATURE

- 1) Rotate the Function selector switch to the Zener diode/Temp position. Press the ALT-F key once for Centigrade, or twice for Fahrenheit measurement.
- 2) Connect the temp adaptor to the meter V/ mA /COMN input sockets as shown in the figure below.
- 3) Connect the thermocouple (K type) to the temp adaptor, observe the polarity.
- 4) Allow at least 10 minutes for connectors of temp adaptor to be stabilized for accurate measurements.
- 5) If no thermocouple is connected to the temp adaptor, the ambient temperature around the adaptor will be measured and displayed.
- 6) The main display reads the temperature in Centigrade or in Fahrenheit, while the secondary display reads the absolute temperature in degrees Kelvin. The Following formulae are used for temperature calculation.

$$0^{\circ}\text{K} = -273.1^{\circ}\text{C}$$

$$0^{\circ}\text{C} = 32^{\circ}\text{F}$$

$$100^{\circ}\text{C} = 212^{\circ}\text{F}$$

$$[^{\circ}\text{C}] = [^{\circ}\text{K}] - 273.1$$

$$[^{\circ}\text{F}] = [^{\circ}\text{C}] \times 9/5 + 32$$

The meter actually measures only the Kelvin degrees ($^{\circ}\text{K}$) and calculates the Centigrade and Fahrenheit temperature ($^{\circ}\text{C}$, $^{\circ}\text{F}$) from the above equations.

- 7) The Temperature adaptor and thermocouple produces 1mV per 1°K at the output terminal marked "V". The meter reads 1°K per mV at the "V" input terminal and 0°K for a 0V input. Therefore 1000°K is an input signal of 1V. This meter can measure the applied voltage at V terminal with an accuracy of 0.05% for an inputs of 0V through 2.5V. Therefore the total accuracy depends upon the accuracy of the temperature adaptor and thermocouple.

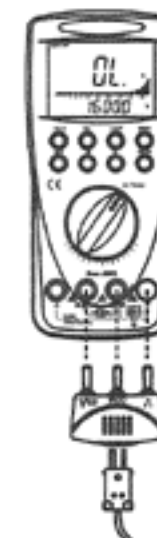

4 RS232C INTERFACE

4-1. CONNECTION BETWEEN PC AND METER

Connect the RS232C cable to the built-in RS232 connector in the meter and to the PC serial port.

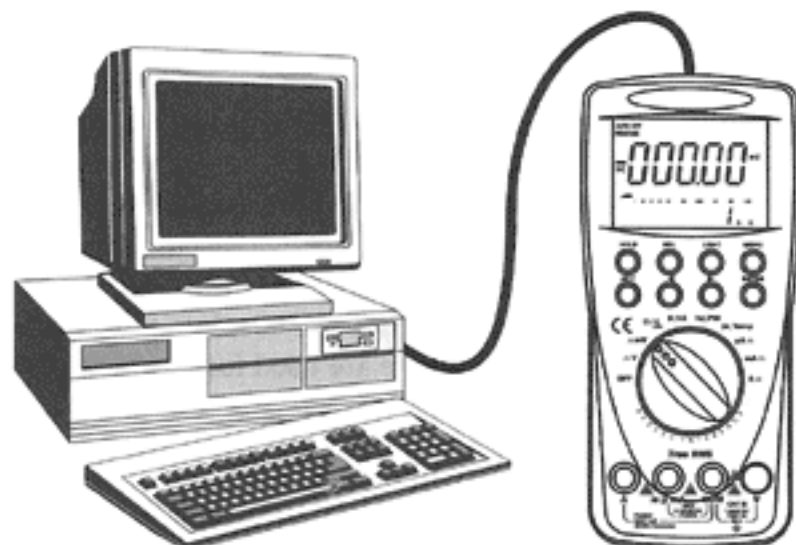

4-2. RS232C CABLE & PIN CONNECTION

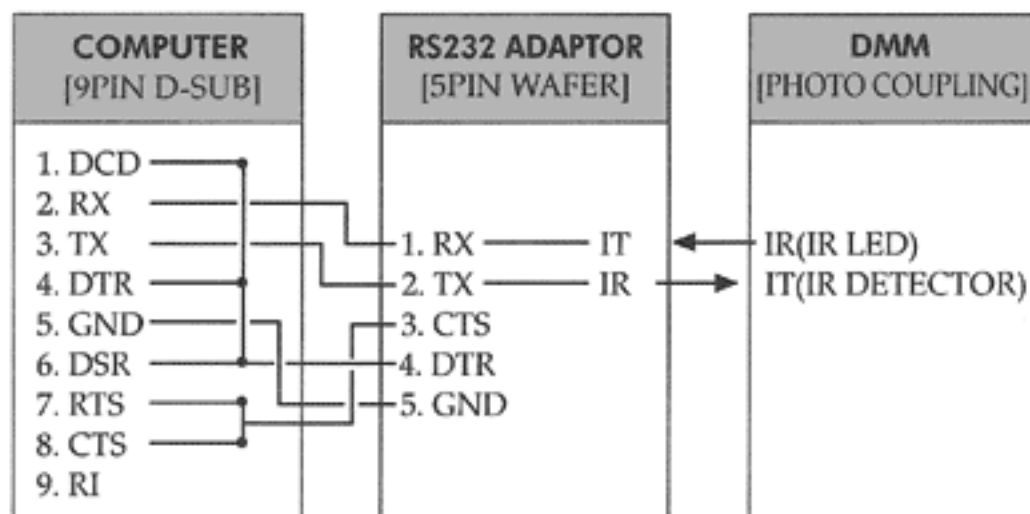

4-3. COMMUNICATION SPEC.

- BAUD RATE : 9600
- DATA BIT : 7
- STOP BIT : 1
- PARITY : NONE

4-4. INSTALLATION

The supplied software programs run on IBM PC compatible computers only.

- 1) Insert the supplied CD ROM into the drive.
There are 2 files on the CD ROM labeled:
WIN 95_98
WIN 3_1
- 2) Type in the following statement from the run command line selected from the START menu if your computer has the WIN95 or WIN 98 operating system D: \setup95 \setup.exe (Press enter) or double click the My Computer icon on the Windows Desk top and click on the D: CD ROM drive icon then click the setup file.exe Icon.
- 3) If your operating system in your computer is WIN 3.1, then type in the following statement in the RUN dialog box.
D: \setup3_1 \setup.exe
or double the click CD-ROM icon on the file manager then select set up 3-1 to execute setup.exe
- 4) Follow the message on the monitor screen.
Refer to the RS232 manual and the read-me file for further details.

4-5. OPERATING

Refer to the help file on the supplied diskette for operating procedure.

5 SPECIAL FUNCTION DESCRIPTION

5-1. AUTO OFF

This Feature is used for conserving battery power. When the meter is left on for more than 15 minutes with out pressing keys or rotating the rotary switch the meter will shut off (go in to Auto power off status). The meter can be restarted by pressing the ENTER key or turning the rotary switch to the off position and then back to its original position. This feature can be disabled by selecting the Auto off annunciator from the menu and then press the enter Key. The Annunciator will disappear from the LCD. This is the continuous use mode; the meter will operate until the battery is drained.

5-2. LOW BATTERY INDICATION

A Battery symbol appears on the display when the battery voltage falls below 6±1V to the Battery symbol warns the user to replace the current battery with a new one.

5-3. BAR GRAPH DISPLAY

This meter has an innovative style of bar graph based on binary bit expression that will indicate a change no matter how small has occurred in the signal level through an easy to understand binary code. The bar-graph segments correspond to the numerical value of the main display's reading. As the input measurement increases, the bargraph segments will increase in a binary sequence

For Example:

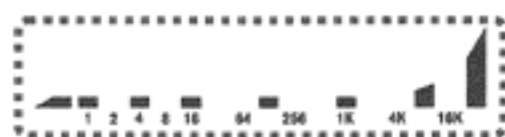

$1 + 4 + 16 + 128 + 1024 + 8192 + 32768 = 42133$ is shown on the main display.

5-4. MAX/MIN

The MAX or MIN capture mode stores the highest or lowest of the measured values into memory and displays them on the main display. The meter can capture and hold signal level changes 100mS or greater in duration. If a shorter capture time is required, use the peak detection mode.

To display the MAX or MIN values,

- 1) Press the menu key
- 2) Press the **Right** or **Left** key to move the blinking cursor to the MAX or MIN.
- 3) Press the **ENTER** key to select and start the MIN or Max capture. To clear the present value of MAX or MIN or restart the capture mode, press the **ENTER** key.

5-5. ± PEAK

The peak detection mode is for capturing high-speed changes in signal level of 5mS or greater in duration. This mode is available only in DCMV, DCV, DCUA, DCMA and DCA. To use this mode press the menu key and move the blinking cursor to + Peak for positive signals or Peak for negative signals with the Right or Left keys then press ENTER. To clear the present value of the peak or to restart the peak detection mode, press the ENTER key only.

5-6. AVERAGE

The AVG function mode is useful for measuring a signal, which contains ripple, noise or fluctuations. Strictly speaking; this AVG function is different from the average by mathematical definition. More exactly it is a smoothing function, which reduces changes due to ripple or fluctuation by 100 times from the following calculation:

$$\text{AVG} = [\text{sum of previous 100 data measured}] / 100$$

5-7. GO/NG

The GO/NG function provides an easy way to determine if a reading falls within a designated range of values. The LCD indicates on the primary display if the input value is out of (fail) or within the range (pass), which you selected. Before starting the GO/NG function, the tolerance range that an input value will be compared against must be set. This can be accomplished with the following procedure.

- 1) Press the menu key.
- 2) Move the blinking cursor to the GO/NG.
- 3) Press the **ENTER** key to select the GO/NG function mode and to enter the input reference value. The display will show the memory address number in the secondary display and the memory contents in the main display used as the reference value.
- 4) There are 2 ways for inputting the reference value.
Method 1: Direct input of reference value by the following method. Press the **ENTER** key for longer than 1sec to modify the contents of the reference memory. The first digit will start blinking. The digit value may be changed by pressing the Left/Right arrow keys. Pressing the **ENTER** key again will cause the second digit to blink. Press the Left/Right keys to change the digit value as required and then press the enter key. This will make the next digit blink. In the same manner, change its value and likewise for all the remaining digits. After the last digit is entered, the-negative sign will blink. Press the Left/Right keys to select positive or negative and press the enter key. This will make the first decimal point

blink. Press the Left/Right keys to move the decimal point to appropriate position and then press the enter key. This completes the input of reference value and displays the +% annunciator on the top right of the display and a blinking secondary display. The +% tolerance is entered through the secondary display by pressing the Right/left keys Pressing the ENTER key will store the + Tolerance value and display the Tolerance annunciator. To enter the % value use the same procedure as for the +% tolerance value. Once the -% tolerance is entered the GO/NO function will start.

5) The second method is the indirect input from one of 10 memories See sections 5-8 and 5-9 below). The data stored in one of the 10 memory locations can be used as the reference by the following procedure: Perform the Steps 1 through 3 in this section. Press the Left/Right keys to select the memory address number where the reference value is stored, then press the ENTER key. This sets the input reference value. To set the +% and % tolerances use the procedure in step 4 above.

5-8. STORE

Up to 10 measurements can be stored or recalled in memory at any time. To store a measurement value in memory

- 1) Press the menu key
- 2) Press the Left/Right arrow keys to position the blinking cursor over the STORE annunciator.
- 3) Press the ENTER key to select the store mode.
- 4) Press the left or right key to select appropriate memory address. The secondary display will show the address number. Pressing the ENTER key stores the displayed measurement reading Note Only numerical data can be stored in memory. OPEN/SHRT Continuity and GO/NG test data cannot be stored in memory
- 5) The memories used for this function are nonvolatile type of EEPROM. So the memory contents are not erased when the batteries go dead or replace. The only way to change the data is by writing new data to a location.

5-9. RECALL

This function recalls data from a memory location that data has been previously stored in: To Recall a memory location:

- 1) Press the menu key.
- 2) Move the Left or right key to position the blinking cursor over recall.
- 3) Press the enter key.
- 4) Press the Left or Right key to select the desired memory address. The main display will read the contents of the memory indicated by the address number on the secondary display.

6 MAINTENANCE

6-1. GENERAL

- 1) Do not use abrasives or solvents. Periodically wipe the case with a damp cloth and detergent.
- 2) Calibrate the meter once a year to maintain the accuracy specified in the attached electrical specification sheet.
- 3) For replacement parts list, refer to the attached list. (Appendices #7-10)

⚠ 6-2. BATTERY REPLACEMENT

Replacing the battery should be done according to the steps below.

- 1) Remove the test leads from the input sockets, and turn off the power.
- 2) Remove the screws from the battery cover and battery cap.
- 3) Lift the battery cover and the discharged battery from the case.
- 4) Carefully disconnect the battery snap connector.
- 5) Snap the battery connector to the new battery terminals. (The new battery must put into the PVC insulation cap.)
- 6) Reinsert the new battery into the case being careful that the battery leads are not pinched between the case and cover.
- 7) Replace the cover and reinstall the screws with a screw driver.



WARNING

DO NOT DISCARD BATTERY CAP

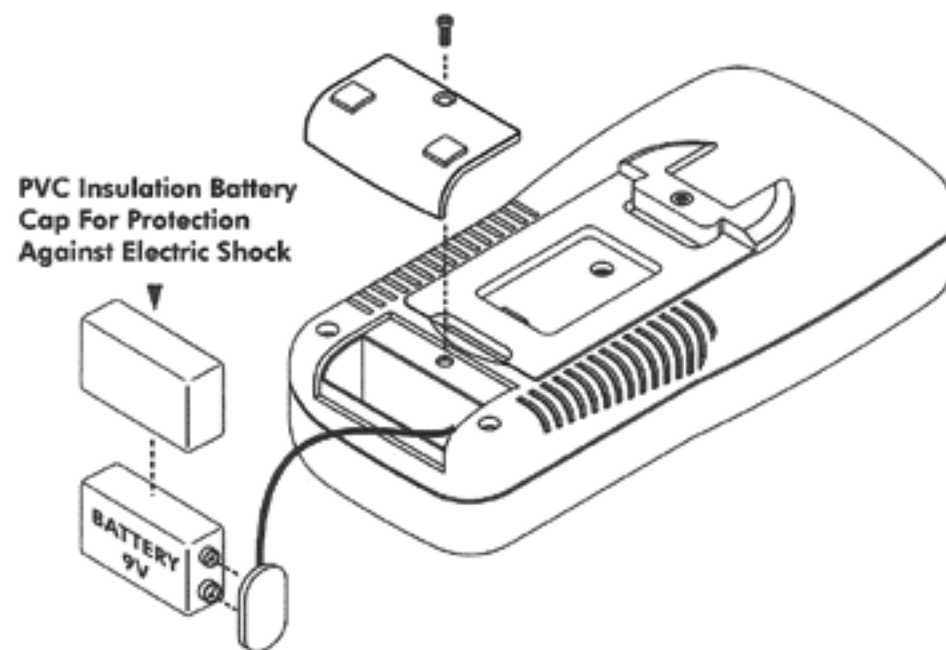

6-3. FUSE REPLACEMENT

Replacing the defective fuse should be done according to the following steps.

- 1) To avoid electrical shock, remove the test leads, any input signal and switch off the meter.
- 2) Remove the battery cover screw, and remove the 3 screws from the bottom case.
- 3) Lift the bottom case until it gently unsnaps from the top case.
- 4) Remove the defective fuse by gently prying loose one end of the fuse and sliding the fuse from the fuse holder.
- 5) Install a new fuse of the same size and rating. Ensure that the new fuse is centered in the fuse holder.
- 6) Replace the bottom case and reinstall all the screws.
(Both fuses must be replaced by qualified service personnel.)

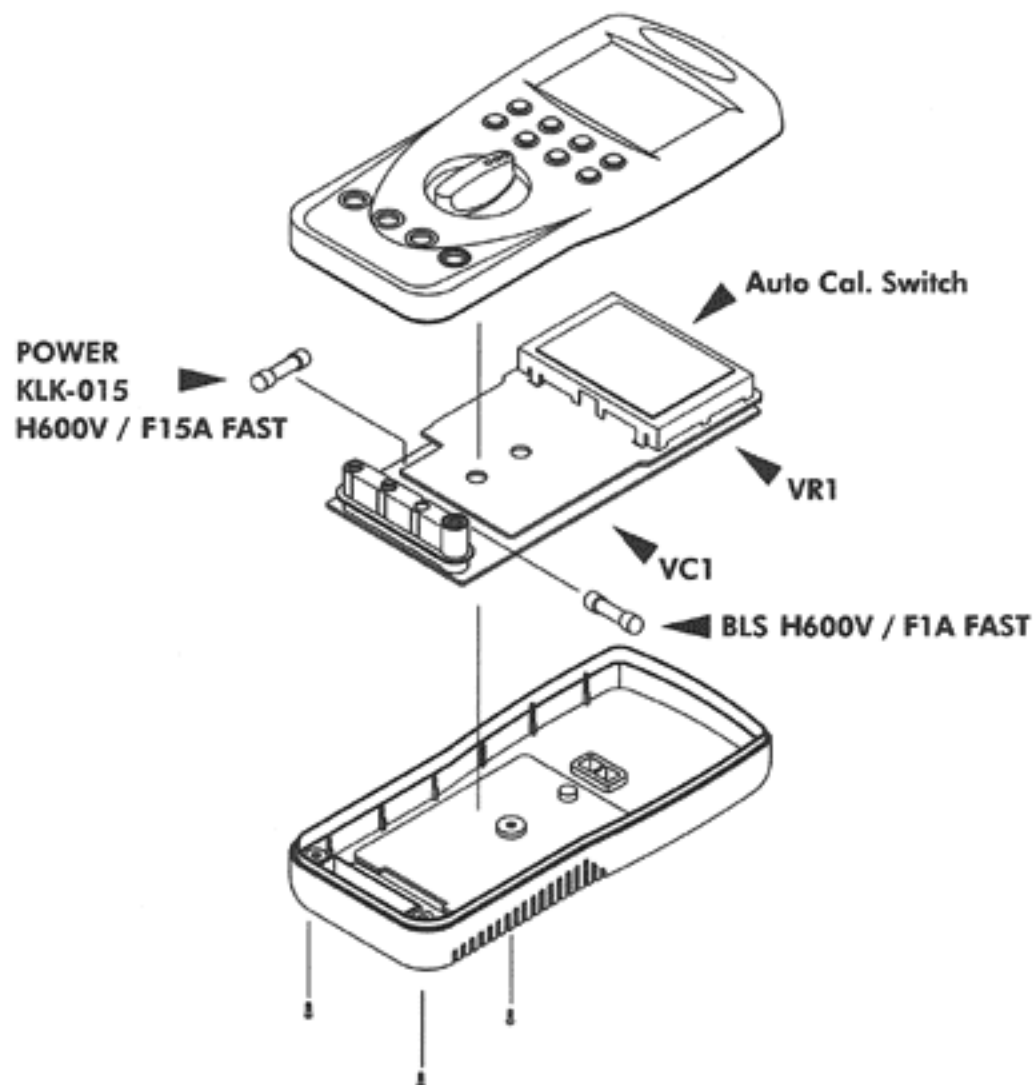

6-4. CALIBRATION

- 1) Turn the power off by turning the rotary switch completely counter clockwise.
- 2) Remove the bottom case by performing steps 1 to 3 of the above for fuse replacement procedure.
- 3) Turn on the switch for auto calibration located at the top of the main PCB
- 4) Replace the bottom case and reinstall all the screw.
- 5) Rotate the rotary function switch to the "V"(volts)position.
- 6) Proceed with the calibration in the order listed on the table below. This calibration should be performed only by qualified service personnel with proper equipment (calibrator, decade resistance/ capacitance etc)
Note: after completion of the calibration, the power switch (rotary switch) must be set to the off position and the auto calibration switch must be returned to the off position.
- 7) Auto calibration procedure

NO.	ROTARY SW POSITION	INPUT TO APPLY (MAIN DISPLAY)	VALUE SHOWN IN SECONDARY DISPLAY	Related Functions	Equipment	Remark
1	V	5V	4.0 to 5.24	DCV	WAVETEK 9100 CALIBRATOR OR BETTER ACCURACY	
2		50V	40 to 52.4			
3		500V	400 to 524			
4		1000V	800 to 1050			
5		5V 50/60Hz	4.0 to 5.24	ACV		
6		50V 50/60Hz	40 to 52.4			
7		500V 50/60Hz	400 to 524			
8		750V 50/60Hz	600 to 800			
9	mV	500mV	400 to 524	DCmV		
10		2500mV	2000 to 2620			
11		500mV 50/60Hz	400 to 524	ACmV		
12	uA	5000uA	4000 to 5240	DCuA		
13		5000uA 50/60Hz	4000 to 5240			
14	mA	500mA	400 to 524	DCmA		
15		500mA 50/60Hz	400to524			
16	A	10A	8 to 10.5	DCA		

NO.	ROTARY SW POSITION	INPUT TO APPLY (MAIN DISPLAY)	VALUE SHOWN IN SECONDARY DISPLAY	RELATED FUNCTIONS	EQUIPMENT	REMARK
17		10A 50/60Hz	8 to 10.5	ACA	DECADE R, C CAN BE USED.	
18	ohm	No input(open)	20000 to 26200	REF V		
19		No input(open)	2000 to 2620	Low REF V		
20		5kohm	4.0 to 5.24	ohm		
21		50kohm	40 to 52.4			
22		500kohm	400 to 524			
23		5Mohm	4.0 to 5.24			
24		50Mohm	40 to 52.4			
25		5kohm	4.0 to 5.24			L.V. ohm
26		50kohm	40 to 52.4			
27		500kohm	400 to 524			
28	5Mohm	4.0 to 5.24				
29	50Mohm	40 to 52.4				
30	Capacitor	50nF	20 to 30	Capacitance		
31		500nF	200 to 300			
32		5uF	2.0 to 3.0			
33		50uF	20to30			

Note The above procedure is programmed into the u-com IC. In the AUTO CAL mode the primary display shows the range to be calibrated, the secondary display will show the calibration data value. Connect the calibrator to the DMM input. Set the calibrator to the setting listed in "input to apply column" If the range needs to be calibrated press the ENTRY key. The display will advance to the next range. If the range is not to calibrated press the Right arrow key. This will skip the step and the original calibration values will not be changed.

8) Manual calibration procedure for trimmer adjustment

NO.	ROTARY SW POSITION	INPUT TO BE APPLIED	TARGET VALUE ON THE DISPLAY	RELATED FUNCTIONS	EQUIPMENT	ADJUST KNOB
1	V	3V 3kHz	3.0000V ±0.0100V	ACV	WAVETEK 9100 OR BETTER	VC 1
2	V	0V(Input Short)	0V ±10 Digits	AC+DCV		VR 1

7 APPENDICES

7-1. GENERAL SPECIFICATION

NO.	ITEM	DESCRIPTION
1	AD Conversion	50,000 Count Resolution, 0.05% Basic Accuracy and 50ms of Sampling Time
2	Conditions for Normal Use	<1 Year Calibration Cycle 23+5°C of Ambient Temperature <90%RH of Humidity & Non-condensing
3	Accuracy Expr.	±(% of Reading + Least Significant Digits)
4	Bar-graph	Binary 17 Bit Expression of Main Digit Decimal
5	Polarity Indication	- For Negative, None for Positive
6	LCD Update Rate	0.5 second typ. Except for the Below Functions 1 to 10 second for Hz, PW, capacitance
7	Memory Locations	10 Memories for storing 10 Measured Data values
8	Power Source	9V Battery, Carbon Zinc or Alkaline Neda1604, 6F22, 006P
9	Auto Power Off	15 min. Typ. After Last Operation of Key or Switch
10	Auto Back Light Off	Automatically Turns off Typically 30 sec. after the Back Light Turned on by Pressing the Light Key.
11	Power Consumption & Battery Life	1) Normal Operating : 7mA typ. which is Equivalent to 36 Hours of Continuous Use with Zinc-carbon Type 9V Battery 2) Auto Power Off : 70uA typ. (Equiv. to 5 Month) 3) Power Switch Off : 7uA Max. (Equiv. to 4 Year)
12	Safety	CE Requirement
13	Temp. Coefficient	<0.1 x Accuracy Spec. / °C for 0 to 18 °C and 28 to 40 °C (32 to 64.4 °F and 82.4 to 104 °F)

NO.	ITEM	DESCRIPTION
14	Operating Temp.	0 to 40°C (32 to 104°F)
15	Relative Humidity	<90%RH at 0 to 28°C (32 to 82.4°F), Non Condensing <80%RH at 28 to 40°C (82.4 to 104°F), Non Condensing
16	Storage Temp.	-20 to 60 °C at <70%RH & Non Condense
17	Basic Accessories	Test Leads, User Manual, Carrying Case, Holster, CD ROM with WIN 95 & WIN 3.1 Software, RS232C Cable
18	Optional Accessories	Temp. Adaptor (608TA) Temp. Probe (K)
19	Low Battery Detect	Battery Indicator on LCD Appears at Below 6±1V.
20	Physical Size (HxWxD)	Main Unit(Net) : 8" x 3.7" x 1.7" (203.5 x 94.0 x 43.2mm) With Holster : 8.5" x 4.1" x 2.25" (216.5 x 104.5 x 58.0mm)
21	Physical Weight	Main Unit(Net) : 14.7 oz(417g) With Holster : 1 lb 3.6oz(557g)

Note**ENVIRONMENTAL CONDITIONS**

This applies to equipment designed for the following conditions:

- indoor use;
- altitude up to 2,000m or above 2,000m if specified by the manufacturer;
- temperature 5°C to 40°C ;
- maximum relative humidity 80% for temperatures up to 31°C decreasing linearly to 50% relative humidity at 40°C;
- transient overvoltages according to INSTALLATION CAT II.
- POLLUTION DEGREE 2.

7-2. ELECTRICAL SPECIFICATION**1. DC mV & V**

FUNCTION	RANGE	ACCURACY	INPUT IMPEDANCE	PROTECTION
DC mV	500.00mV	0.05% + 5d	>1Gohm	MAX. 250VAC or DC (5kohm PTC)
	2500.0mV			
DCV	5.0000V		About 10.5 Mohm	MAX. 1000VDC or 750VAC (10Mohm)
	50.000V		About 10.05 Mohm	
	500.00V	About 10 Mohm		
	1000.0V	About 10 Mohm		

2. AC mV & V

FUNCTION	RANGE	ACCURACY FOR EACH FREQUENCY RANGE					
		50 to 500Hz	UP to 1kHz	UP to 5kHz	UP to 10kHz	UP to 20kHz	
AC mV	500.00mV	0.75% + 20d for <400mV 1% for >400mV		1.5% for >50mV	2% for >50mV	3% for >50mV	
AC V	5.0000 V	0.75% + 20d	1% for ACV Level >10% of Full Scale		2% for ACV >10% of Full Scale		Not Specified
	50.000 V						
	500.00 V						
	750.0 V						

Note

- 1) Input impedance for ACmV : >1Gohm shunted with 100pF typ.
For ACV : About 10Mohm shunted with 30pF typ.
- 2) Applicable crest factor : Max. 3 for full scale
Additional error and crest factor for various waveforms

WAVE FORM	CREST FACTOR	ADDITIONAL ERROR
SQUARE	1	0.20%
SINE	1.414	0%
TRIANGLE	1.73	0.30%
OTHERS	2	0.50%
	3	1.70%

- 3) Protection for ACmV : Max 250VAC or DC with 5kohm PTC
For ACV : Max 1000VDC or 750VAC with 10Mohm

3. AC+DC mV & V

FUNCTION	RANGE	ACCURACY FOR EACH FREQUENCY RANGE				
		50 to 500Hz	UP to 1kHz	UP to 5kHz	UP to 10kHz	UP to 20kHz
AC+DC mV	500.00mV	1.5% +50d for <300mV 2.0% for >300mV		2.5% for >50mV	3.5% for >50mV	4.5% for >50mV
AC+DC V	5.0000 V	2.0% +50d	2.5% for AC+DC V Level ≥10% of Full Scale	3.5% for AC+DC V >10% of Full Scale	Not Specified	
	50.000 V					
	500.00 V					
	750.0 V					

Note

Input impedance, crest factors and protection are the same as those described in AC mV & AC V.

4. DC current

FUNCTION	SHUNT	RANGE	ACCURACY	PROTECTION
DC uA	100 ohm	5000.0 uA	0.2% +5d	1A/600V Fast Fuse & 22V M.O.Varistor
DC mA	1 ohm	500.00 mA		
DC A	10Mohm	10.000 A	0.5% +5d	15A/600V Fast Fuse

Note

- 1) Burden voltage : Test current x (Shunt R + Fuse R)
- 2) The "A" input terminal allows continuous current flow up to 5A; within 3 minutes up to 10A or within 30 seconds up to 15A. Successive high current measurements above 5A requires 10minutes of cooling time between measurements.

5. AC current

FUNCTION	RANGE	FREQUENCY	ACCURACY	PROTECTION
AC uA	5000.0 uA	50Hz to 1kHz	0.75% +20d for <40000count 1% for >40000count	1A/600V Fast Fuse & 22V M.O.Varistor
AC mA	500.00 mA			15A/600V Fast Fuse
AC A	10.000 A			

Note

- 1) Burden voltage : Same as in DC current
- 2) True RMS crest factor : Same as in AC V
- 3) Frequency response up to 20kHz, the same as ACmV.

6. AC+DC current

FUNCTION	RANGE	FREQUENCY	ACCURACY	PROTECTION
AC+DC uA	5000.0 uA	DC to 1kHz	1.5% +50d for <30000count 2% for >30000count	1A/600V Fast Fuse & 22V M.O.Varistor
AC+DC mA	500.00 mA			15A/600V Fast Fuse
AC A	10.000 A			

Note

- 1) Burden voltage : Same as in DC current
- 2) True RMS crest factor : Same as in AC V
- 3) Frequency response up to 20kHz is the same as those for AC+DCmV.

7. Resistance

RANGE	RESOL.	ACCURACY	OPEN/SHORT	PROTECTION
50.00 ohm	0.01 ohm	1.0% +20d	2.5V / 1.7mA	250VAC or DC (500 ohm PTC)
5.0000 kohm	0.1 ohm	0.2% +5d	2.5V / 1.7mA	
50.000 kohm	1 ohm		2.5V / 240uA	
500.00 kohm	10 ohm		2.5V / 25uA	
5.0000 Mohm	100 ohm		2.5V / 2.5uA	
50.000 Mohm	1k ohm	1.0% +10d	2.5V / 250nA	

Note

When testing high resistance in Mohm range, good Shielding and extremely short test leads is recommended for accurate measurement and for avoiding instability due to external noise.

8. LV ohm (Low Voltage OHM)

RANGE	RESOL.	ACCURACY	OPEN/SHORT	PROTECTION
5.000 kohm	1 ohm	0.5% +5d	0.25V / 170uA	250VAC or DC (500 ohm PTC)
50.00 kohm	10 ohm		0.25V / 24uA	
500.0 kohm	100 ohm		0.25V / 2.5uA	
5.000 Mohm	1k ohm		0.25V / 250uA	
50.00 Mohm	10k ohm	2.5% +10d	0.25V / 25nA	

Note

This LV ohm is very useful function in your checking a complex PCB

assembly, because its testing voltage is low enough to treat regard semiconductors as open circuit and therefore you can check exact resistance value of each component without removing semiconductors or breaking the PCB patterns connected to them.

9. nS

RANGE	RESOL.	ACCURACY	OPEN/SHORT	PROTECTION
500.0 nS	0.1 nS	3.0% +5d	2.5V / 25 nA	250VAC or DC

Note

1) $S = 1/R$

Where S : Siemens, R : Resistance

500nS corresponds to 2Mohm, 0.1nS to 10Gohm.

2) Careful attention for shielding from noise in very high resistance

10. CONTINUITY

RANGE	INPUT	RESPONSE	ACCURACY	PROTECTION
5 kohm	Short	Buzzer On	<5 ohm	250VAC or DC (500 ohm PTC)
	Open	Buzzer Off	>15 ohm	
50 kohm	Short	Buzzer On	<50 ohm	
	Open	Buzzer Off	>100 ohm	
500 kohm	Short	Buzzer On	<500 ohm	
	Open	Buzzer Off	>1 kohm	
5 Mohm	Short	Buzzer On	<5 kohm	
	Open	Buzzer Off	>10 kohm	

11. ZENER DIODE

RANGE	ACCURACY	TEST CURRENT	OPEN CIRCUIT V	PROTECTION
15.000 V	5% +10d	1mA	15 to 22V	250VAC or DC (500 ohm PTC)

Note

1) Zener diode voltage from 0V up to the open circuit voltage (15 to 22V) can be conveniently measured with 1mA constant current source circuit built in to this meter.

2) This function can be used as constant current source with high accuracy of $1mA \pm 5\%$ for compliance voltage of about 20V.

12. Capacitance

RANGE	RESOL.	ACCURACY	TESTING TIME	PROTECTION
5.000 nF	1 pF	5% +10d	1.1 Sec.	250VAC or DC (500 ohm PTC)
50.00 nF	10 pF	2% +10d		
500.0 nF	100 pF			
5.000 uF	1 nF	2% +5d	VARIABLE (1.1 to 10 Sec)	
50.00 uF	10 nF			
500.0 uF	100 nF	3% +10d		
5.000 mF	1 uF			

13. Frequency

RANGE	RESOL.	ACCURACY	INPUT IMPEDANCE	PROTECTION
50.00 Hz	0.01 Hz	0.01% +5d	10Mohm // 1nF	500VAC or DC (1kV 1nF Capacitor Parallel with 10M 1/2W Resistor)
500.0 Hz	0.1 Hz			
50.000 kHz	1 Hz			
500.00 kHz	10 Hz			
5.0000MHz	100 Hz			

Note

1) Sensitivity : Max. 2VAC or 4Vp-p from 5Hz through 5MHz

2) Secondary display shows AC volt measurement value simultaneously with frequency in main display. The specification for this ACV is shown in the previous item no. 2.

14. Pulse width

RANGE	RESOL.	ACCURACY	INPUT IMPEDANCE	PROTECTION
200.00 ms	10u Sec.	0.1% +5d	10Mohm//1nF	500VAC or DC

Note

Sensitivity : same as for frequency

15. Duty cycle

RANGE	RESOL.	ACCURACY	PULSE WIDTH	PROTECTION
100.00 %	0.01%	0.1% +5d	0.1ms to 200ms	500VAC or DC

16. Temperature

RANGE	RESOL.	RANGE	ACCURACY	PROTECTION
°C	0.1°C	-20 to 0°C	±3°C	Max. 500VAC or DC for V Terminal, 1A 600V Fast Fuse for mA Terminal
		0 to 150°C	±2°C	
		150 to 1200°C	±2 %	
°F	0.1°F	°F= 32+(9/5x°C)		
°K	0.1°K	°K=°C+273.1		

Note

Temp. Sensor : K-type probe whose accuracy should be added to the above accuracy.

17. Peak +/- detection

FUNCTION	ACCURACY	REMARK
DCmA	Less than 10% for peak with >5ms of duration and with >10% of full scale of each range	
DCV		
DCuA		
DCmA		
DCA		

18. Protection

TERMINAL	FUNCTION	MAXIMUM INPUT	PROTECTION DEVICE
V	DCV, ACV	1000VDC or AC Peak	10M 1/2W Resistor
	Hz, Temp.	500VDC or AC RMS	10pF 1kV Capacitor
	Others	250VDC or AC RMS	PTC(500ohm, 5kohm)
u/mA	0.5A DC or AC RMS		1A 600V Fast Fuse
10A	10A DC or AC RMS		15A 600V Fast Fuse

7-3. RANGE SWITCHING BY FUNCTION

NO.	FUNCTION	RANGE	SELECTION METHOD	OPERATION KEY
1	DC V	4	AUTO & MANUAL	◀ ▶
2	AC V	4	AUTO & MANUAL	◀ ▶
3	AC+DC V	4	AUTO & MANUAL	◀ ▶
4	DCmV	2	AUTO & MANUAL	◀ ▶
5	ACmV	1	FIXED	
6	AC+DCmV	1	FIXED	
7	ohm	6	AUTO & MANUAL	◀ ▶
8	CONTINUITY	4	AUTO & MANUAL	◀ ▶
9	LV-ohm	5	AUTO & MANUAL	◀ ▶
10	CAPACITANCE	7	AUTO & MANUAL	◀ ▶
11	SUSCEPTANCE	1	FIXED	
12	Hz	5	AUTO & MANUAL	◀ ▶
13	+PULSE WIDTH	1	FIXED	
14	- PULSE WIDTH	1	FIXED	
15	ZENER DIODE	1	FIXED	
16	TEMP:(°C)	1	FIXED	
17	TEMP:(°F)	1	FIXED	
18	DCuA	1	FIXED	
19	ACuA	1	FIXED	
20	AC+DCuA	1	FIXED	
21	DCmA	1	FIXED	
22	ACmA	1	FIXED	
23	AC+DCmA	1	FIXED	
24	DC A	1	FIXED	
25	AC A	1	FIXED	
26	AC+DC A	1	FIXED	

* Indication for over-range : "OL" on LCD display

* Over-range : In excess of full scale

* Under-range : Under 9% of full scale

* In some special modes such as max, min ,avg, REL etc., "49999" is displayed instead of "ol".

7-4. MODE SELECTION BY FUNCTION

NO.	FUNCTIONS	HOLD	RANGE	REL	MAX	MIN	AVG	A/OFF	RS232	PEAK	GO/NG	STORE	RECALL
1	DC V	○	○	○	○	○	○	○	○	○	○	○	○
2	AC V	○	○	○	○	○	○	○	○		○	○	○
3	AC+DC V	○	○	○	○	○	○	○	○		○	○	○
4	DCmV	○	○	○	○	○	○	○	○	○	○	○	○
5	ACmV	○		○	○	○	○	○	○		○	○	○
6	AC+DCmV	○		○	○	○	○	○	○		○	○	○
7	ohm	○	○	○	○	○	○	○	○		○	○	○
8	CONTINUITY	○	○					○	○				
9	LV-ohm	○	○	○	○	○	○	○	○		○	○	○
10	CAPACITANCE	○	○	○	○	○	○	○	○		○	○	○
11	SUSCEPTANCE	○		○	○	○	○	○	○		○	○	○
12	Hz	○	○		○	○	○	○	○		○	○	○
13	+PULSE WIDTH	○			○	○	○	○	○		○	○	○
14	-PLUSE WIDTH	○			○	○	○	○	○		○	○	○
15	ZENER DIODE	○		○	○	○	○	○	○		○	○	○
16	TEMP(C)	○		○	○	○	○	○	○		○	○	○
17	TEMP(F)	○		○	○	○	○	○	○		○	○	○
18	DCuA	○		○	○	○	○	○	○	○	○	○	○
19	ACuA	○		○	○	○	○	○	○		○	○	○
20	AC+DCuA	○		○	○	○	○	○	○		○	○	○
21	DCmA	○		○	○	○	○	○	○	○	○	○	○
22	ACmA	○		○	○	○	○	○	○		○	○	○
23	AC+DCmA	○		○	○	○	○	○	○		○	○	○
24	DC A	○		○	○	○	○	○	○	○	○	○	○
25	AC A	○		○	○	○	○	○	○		○	○	○
26	AC+DCA	○		○	○	○	○	○	○		○	○	○

7-5. SPECIAL SYMBOLS ON LCD

NO.	FUNCTIONS	DESCRIPTION
1	∞)	Continuity test mode
2	⚡	Zener diode test
3	🔋	Low battery indication
4	REL	Relative mode
5	RECALL	Reads the data stored in memory
6	STORE	Stores the measured data into memory
7	RS232C	Serial data interface with computer
8	AUTO OFF	Automatic power off, 15 minutes after the last key or switch operation
9	±PULSE	Indicates the polarity of the pulse being measured in pulse width and duty cycle function.
10	±PEAK	Indicates the polarity of the peak measured in measuring the peak value of voltage or current.
11	MAX	Maximum value in a measurement.
12	MIN	Minimum value in a measurement.
13	AVG	100 measurements are averaged.
14	GO/NG	Go/no-go test mode
15	REF	Reference value for go/ng test
16	PW	Pulse width test mode
17	RANGE	Indicates manual range mode
18	HOLD	Indicates the data hold key was pressed.
19	DUTY	Duty cycle test
20	dBm	Decibel based on 1mw/600 ohm

7-6. LCD STATUS BY FUNCTIONS AUTO OFF

1) Full Display (Power On)

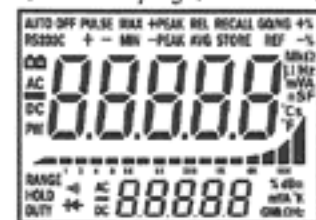

2) DC V

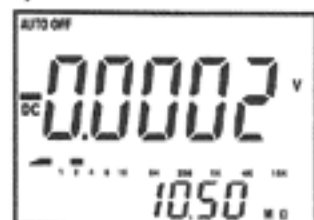

3) AC V



4) AC+DC V

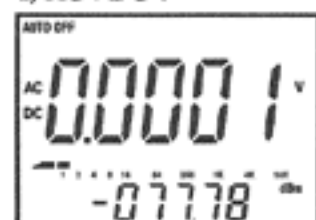

5) DCmV



6) ACmV

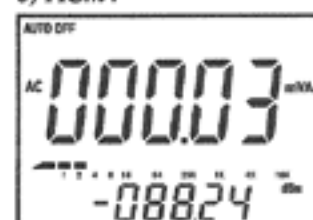

7) AC+DCmV



8) ohm

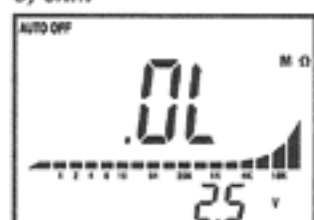

9) Continuity



10) LV ohm

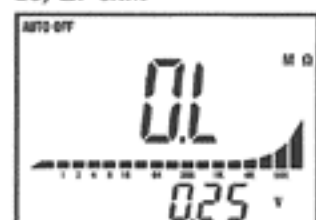

11) Capacitance

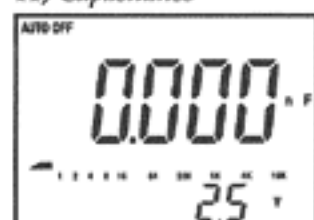

12) nS (nano Susceptance)



13) Frequency



14) +Pulse Width



15) -Pulse Width



16) Zener Diode

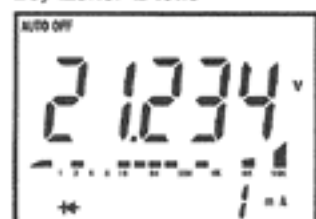

17) Temperature (°C)



18) Temperature (°F)



19) DCuA



20) ACuA



21) AC+DCuA

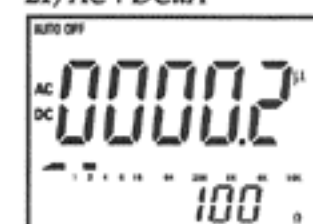

22) DCmA



23) ACmA



24) AC+DCmA



25) DC A



26) AC A



27) AC+DC A

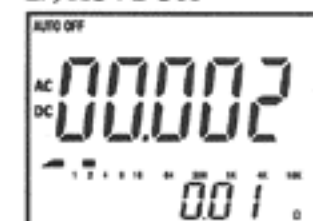

7-7. LCD STATUS BY MODES

1) Hold



2) Range

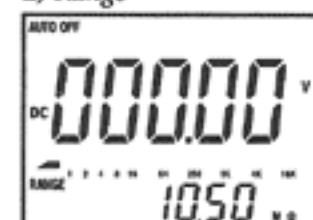

3) RS232C



4) Low battery indication



5) Max

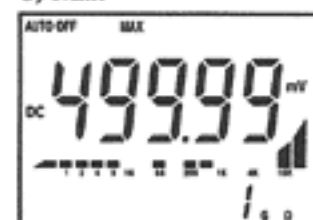

6) Min

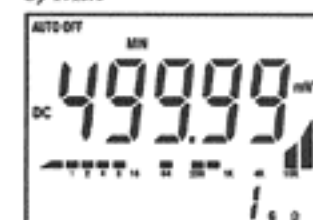

7) +Peak



8) -Peak



9) Average



10) Recall



11) Store



12) GO/NG REF



13) GO/NG +%

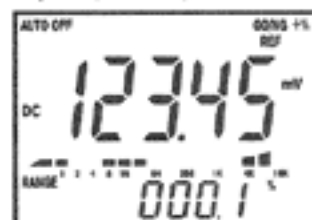

14) GO/NG -%



15) GO/NG Pass



16) GO/NG Fail

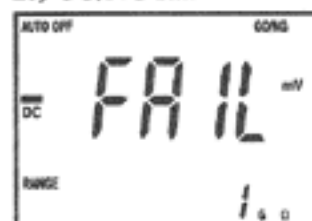

17) Menu



7-8. ASSEMBLY DIAGRAM

1. Main Unit Assembly

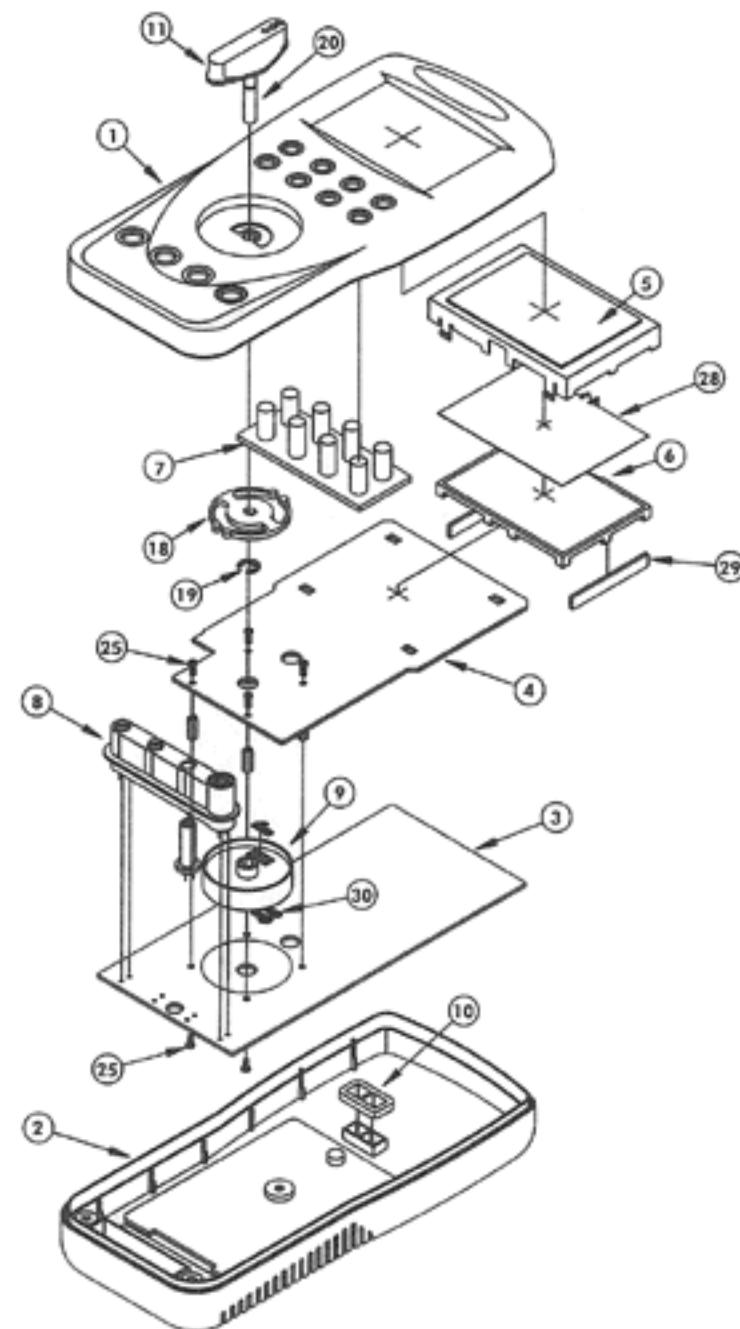

2. Rear Panel & Rs232 Cable Assembly

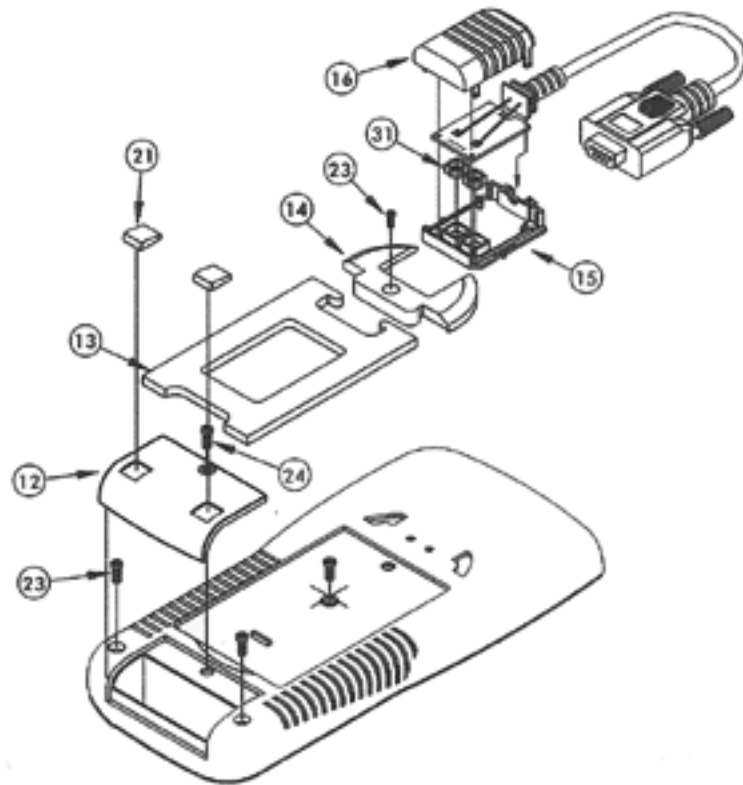

3. Temp Adaptor Assembly

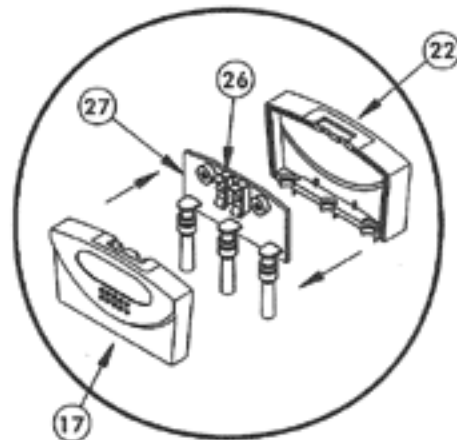

4. Assembly Parts List

NO.	DESCRIPTION	SPECIFICATION	Q'TY
①	CASE TOP	M333065-C001A	1
②	CASE BOTTOM	M333065-C002A	1
③	PCB BOTTOM	M333065-C004A	1
④	PCB TOP	M333065-C003A	1
⑤	WINDOW	M333065-C005A	1
⑥	LCD HOLDER	M333065-C015A	1
⑦	KEY PAD	M333065-C014A	1
⑧	INPUT SOCKET ASS'Y	M333065-C011A	1
⑨	HOLDER CONTACT	M333065-C010A	1
⑩	COVER SENSER(1)	M333065-C017A	1
⑪	KNOB ROTATOR	M333065-C006A	1
⑫	COVER BATTERY	M333065-C007A	1
⑬	STAND	M333065-C009A	1
⑭	HOLDER RS232C	M333065-C013A	1
⑮	BOTTOM RS232C	M333065-C018A	1
⑯	TOP RS232C	M333065-C019A	1
⑰	TOP ADAPTOR	M333065-C019	1
⑱	ROTATOR	M333065-C008A	1
⑲	E-RING	4.0PI*0.6T	1
⑳	KNOB ROTATOR INSERT	M333065-C031A	1
㉑	FOOT RUBBER	M333065-C016A	2
㉒	BOTTOM ADAPTOR	M333065-C020A	1
㉓	MACHINE SCREW	PH(+) M 3.0*6.0 BLACK	4
㉔	MACHINE SCREW	FH(+) M3.0*6.0 BLACK	1
㉕	MACHINE SCREW	PH(+) M2.3*6 WASHER NI/PL	8
㉖	CONNECTOR-TAMP	M333065-C002A	2
㉗	PCB ADAPTOR	M333065-C024A	1
㉘	BACK RIGHT		1
㉙	LCD ZEBRA	M332008-C026A SILICON&CARBON	2
㉚	SLIDE CONTACT	C5210S-SH T0.15	3
㉛	COVER SENSER	M333065-C021A	2

⚠ 7-9. SAFETY

1. Safety : 1000VDC or 750VAC of maximum voltage between v terminal, com terminal and earth ground. This product meets the safety requirements for a safety class 2 (Reinforced Insulation) and does not require grounding for safety.
2. Installation category : IEC664, over voltage category II
3. Protection
 - 1) Surge : 8kV peak per EN 61000-4-2
 - 2) Fuse : F15A H600V fast Fuse for "A" Terminal.
F1A H600V fast Fuse for "mA" Terminal.
(Both fuses must be replaced by qualified service personnel.)
4. Electrical symbols used here are shown below.

	AC (ALTERNATING CURRENT)		CAUTION, RISK OF ELECTRIC SHOCK
	DC (DIRECT CURRENT)		EARTH GROUND
	AC, DC OR AC + DC		CAUTION, SEE EXPLANATION IN MANUAL
	DOUBLE INSULATION OR REINFORCED INSULATION		

5. Safe operating conditions
 - 1) Do not measure voltage in excess of 1000V peak.
 - 2) Observe the maximum input as stated in the specification.
 - 3) Disconnect the test lead from the test points before changing the meter function and range.
 - 4) Be careful not to touch the terminals or probe tip when measuring above 60VDC or 25VAC.
 - 5) Never attempt a voltage measurement with a test lead in the "A" or mA input terminal.
 - 6) Do not measure more than 10A(which will display "OL") and do not continue measuring high current above 10A for more than 3 minute. To avoid opening fuse and overheating circuits. The successive measurement should be done after more than 10 minutes for cooling down.
 - 7) Do not attempt a current measurement when the voltage is above 600V.
 - 8) Remove the test leads before opening the case to avoid electrical shock.
 - 9) Disconnect the live test lead before disconnecting the common test lead.
 - 10) Install only the fuses with the specified AMP/VOLT ratings.

7-10. REPLACEMENT PARTS LIST

NO.	ID NO.	NAME	SPECIFICATION	REFERENCE
1	F11-F001-36612	FUSE	1A/600V [BLS]	F1
2	F11-F001-36613	FUSE	15A/600V [KLK-015]	F2
3	B9-B001-00304	BATTERY	9V(GF22)	
4	C23-T001-42545	TESTER CORD	HC608	
5	C42-T001-05574	TEMP PROBE	2030ET,3500T,5020T,4500E	
6	D05-C001-42483	CD	HC608(J3D2-99410)	
7	M02-M001-42546	MANUAL	HC608(J3D2-99411)	
8	T16-T001-39257	TEMP ADAPTOR	HC608	
9	R21-R001-39273	RS232C CABLE	HC608	
10	C34-T001-39399	TOP CASE	HC608	
11	P02-K001-39248	KEY PAD	HC608(SIL M333065-C014A)	
12	K04-K001-39416	KNOB	ROTATOR(HC608)	
13	R10-R001-39252	ROTATOR	HC608(ACE M333065-C008A)	
14	R08-E001-25070	E-RING	4.0PI*0.6T BLACK/PL	
15	C34-B001-39398	BOTTOM CASE	HC608	
16	H13-H002-39400	HOLDER RS232C	RS232C(HC608)	
17	S06-I002-42363	INSULATION SHEET	M333065-C036A PVC T 0.3(HC608)	
18	P11-S003-42362	SHIELD PLATE	M333065-C035A A1100 T 0.2(HC-608)	
19	C26-S002-39242	SENSOR COVER(1)	HC608(ACE M333065-C017A)	
20	S17-S001-39255	STAND	HC608(ABS M333065-C009A)	
21	C26-B003-39241	BATTERY COVER	HC608(ABS M333065-C007A)	
22	R11-R001-39253	RUBBER FOOT	HC608(NEOPRENE M333065-C016A)	
23	P27-M001-36632	MAIN PCB ASS'Y	HC608(LINE)	
24	W04-W001-39258	WINDOW	HC608(ACR M333065-C005A)	
25	L02-L001-36629	LCD	HC608(AT4427AZR)	
26	H03-L002-39247	LCD HOLDER	HC608(ABS M333065-C015A)	
27	Z01-L001-36659	LCD ZEBRA	HC608 SILICON	
28	P27-S001-36633	SUB PCB ASS'Y	HC608(LINE)	
29	P15-H001-14197	HEXAGON POLE	BSBM M2.3*L:10.0(5010,80U,90G)	
30	H03-C005-39245	CONTACT HOLDER	HC608(ACE M333065-C010A)	
31	C22-S001-04351	SLIDE CONTACT	PBS-SH 0.15T(301U,1015U)	
32	G04-S001-34048	SPARK GAP	DS15N 1.5KVDC	SG1,SG2
33	T04-P001-24431	PTC THERMISTOR	500 ohm (911P97E501YU100) [TDK]	PTC2,PTC3
34	S02-M001-25702	MACHINE SCREW	BH(+)M2.3*0.4P*5.0 NI/PL	
35	S02-M001-18308	MACHINE SCREW	BH(+)M3.0*0.5*6.0 BLACK	
36	S02-M001-18309	MACHINE SCREW	BH(+)M3.0*0.5*8.0 BLACK	
37	S02-M001-18339	MACHINE SCREW	FH(+)M3.0*0.5*6.0 BLACK	
38	S02-M001-18417	MACHINE SCREW	PH(+)M3.0*0.5*8.0 BLACK	
39	C04-B002-43603	BATTERY CAP	M333065-C03BA BLISTER(HC-608)	

1	2	3	4	5	6	7	8	REMARK
7B	7G	7C	P7	7A	7F	7E	7D	SUB DIGIT 3
9	10	11	12	13	14	15	16	
8B	8G	8C	P8	8A	8F	8E	8D	SUB DIGIT 4
17	18	19	20	21	22	23	24	
9B	9G	9C	P9	9A	9F	9E	9D	SUB DIGIT 5
25	26	27	28	29	30	31	32	
←	RANGE	HOLD	DUTY	→))	AC	=	DC	25-32 SUB UNIT
33	34	35	36	37	38	39	40	
B0	B1		PW	B2	B4	B8	B16	B=BAR GRA.
41	42	43	44	45	46	47	48	
⊞	AC	=	DC	4A	4F	4E	4D	MAIN DIGIT 5
49	50	51	52	53	54	55	56	
4B	4G	4C	P4	3A	3F	3E	3D	MAIN DIGIT 4
57	58	59	60	61	62	63	64	
3B	3G	3C	P3	2A	2F	2E	2D	MAIN DIGIT 3
65	66	67	68	69	70	71	72	
2B	2G	2C	P2	-	+			
73	74	75	76	77	78	79	80	
PULSE		AUTO OFF	RS232C	MIN	-PEAK	AVG	STORE	
81	82	83	84	85	86	87	88	
MAX	+PEAK	REL	RECALL	+%	-%	REF	GO/NG	
89	90	91	92	93	94	95	96	
1A	1F	1E	1D	1B	1G	1C	P1	MAIN DIGIT 2
97	98	99	100	101	102	103	104	
0A	0F	0E	0D	0B	0G	0C		MAIN DIGIT 1
105	106	107	108	109	110	111	112	
	Hz	'F	s		OHM	A	F	
113	114	115	116	117	118	119	120	
k	V	S	'C	M	u	m	n	
121	122	123	124	125	126	127	128	
		B16K	B8K	B512	B1K	B2K	B4K	BAR GRAPH
129	130	131	132	133	134	135	136	
B256	B128	B64	B32	%	m	G	M	B=BAR GRA.
137	138	139	140	141	142	143	144	
dBm	V	OHM	k	'K	A	Hz		133-143 SUB UNIT
145	146	147	148	149	150	151	152	
5B	5G	5C		5A	5F	5E	5D	SUB DIGIT 1
153	154	155	156	157	158	159	160	
6B	6G	6C	P6	6A	6F	6E	6D	SUB DIGIT 2
161	162							

* First 1 - Byte is composed of 5B(HEX) or "I"(CHAR).
 Last 1- Byte(43rd Byte) is composed of 5D(HEX) or "I"(CHAR).
 When this is detected, it means all data on LCD received.

Communication protocol

Baud rate : 9600bps

Data bit : 7-bit

Stop bit : 1-bit

Parity : No

1-Byte is composed of 7 bits, but effective bits are lower 4 bits.

The data of 41 Bytes(162 bits) except first and last Bytes have separate meaning according to each bit.

SEND DATA (HEX)

- * HOLD = 5
- * LIGHT = 7
- * RANGE = 6
- * MENU = 8
- * ALT_F = 1
- * LEFT = 2
- * RIGHT = 3
- * ENTER = 4

<WARRANTY>

This product is warranted against all defects of material or workmanship which may develop for any reason whatsoever, except abuse, within a period of one year from the date of purchase by the original buyer of user.

Any product found defective during the warranty period and returned to the factory will be repaired, adjusted or replaced at no charge to the original purchaser. This warranty does not cover expendable items such as battery or fuse. If the defect has been caused by misuse or abnormal operating conditions, the repair will be billed to the user.